

Features

- 2-channel isolated barrier
- 24 V DC supply (Power Rail)
- Thermocouple, RTD, potentiometer or voltage input
- Usable as signal splitter (1 input and 2 outputs)
- Voltage output 0/1 V ... 5 V
- Configurable by PACTware
- Line fault (LFD) and sensor burnout detection
- Up to SIL 2 acc. to IEC 61508/IEC 61511

Function

This isolated barrier is used for intrinsic safety applications. The device converts the signal of a resistance thermometer, thermocouple, or potentiometer to a proportional output voltage. The device can also be configured as a signal splitter. The removable terminal block K-CJC-** is available as an accessory for internal cold junction compensation of thermocouples. A fault is signaled by LEDs acc. to NAMUR NE44 and a separate collective error message output. The device is easily configured by the use of the PACTware configuration software. For additional information, refer to the manual and

Assembly

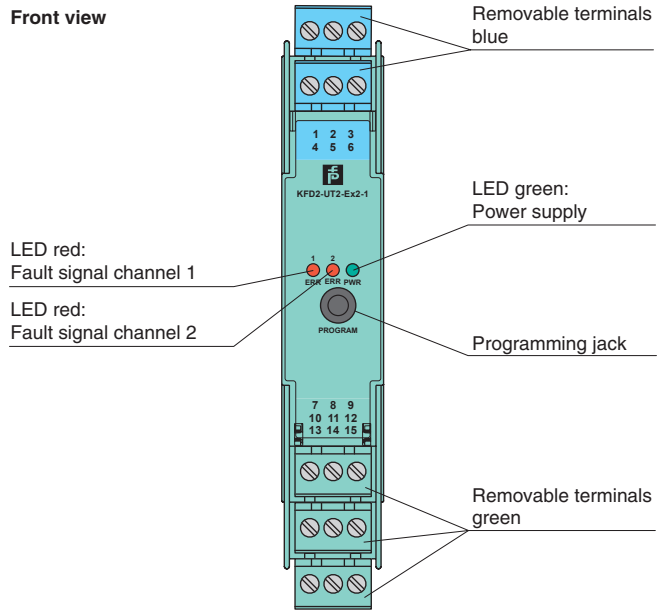

SIL 2

Connection

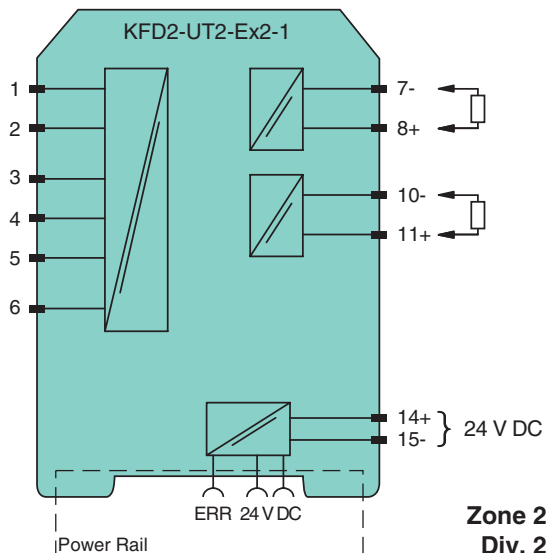
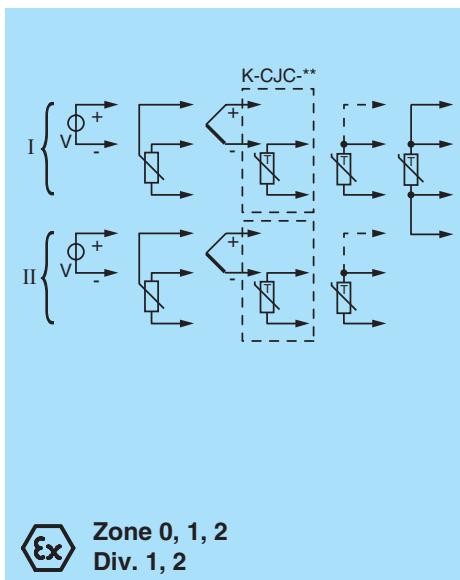

Release date 2019-01-25 09:38 Date of issue 2019-01-25 248768_eng.xml

General specifications	
Signal type	Analog input
Functional safety related parameters	
Safety Integrity Level (SIL)	SIL 2
Supply	
Connection	terminals 14+, 15- or power feed module/Power Rail
Rated voltage U_r	20 ... 30 V DC
Ripple	within the supply tolerance
Power dissipation/power consumption	$\leq 0.8 \text{ W} / 0.8 \text{ W}$
Interface	
Programming interface	programming socket
Input	
Connection side	field side
Connection	terminals 1, 2, 3; 4, 5, 6
RTD	type Pt10, Pt50, Pt100, Pt500, Pt1000 (EN 60751: 1995) type Pt10GOST, Pt50GOST, Pt100GOST, Pt500GOST, Pt1000GOST (6651-94) type Cu10, Cu50, Cu100 (P50353-92) type Ni100 (DIN 43760)
Measuring current	approx. 200 μA with RTD
Types of measuring	2-, 3-wire connection
Lead resistance	$\leq 50 \Omega$ per line
Measurement loop monitoring	sensor breakage, sensor short-circuit
Thermocouples	type B, E, J, K, N, R, S, T (IEC 584-1: 1995) type L (DIN 43710: 1985) type TXK, TXKH, TXA (P8.585-2001)
Cold junction compensation	external and internal
Measurement loop monitoring	sensor breakage
Potentiometer	0 ... 20 k Ω (2-wire connection), 0.8 ... 20 k Ω (3-wire connection)
Voltage	selectable within the range -100 ... 100 mV
Input resistance	$\geq 1 \text{ M}\Omega$ (-100 ... 100 mV)
Output	
Connection side	control side
Voltage output	0 ... 5 V or 1 ... 5 V ; output resistance: $\leq 5 \Omega$; load: $\geq 10 \text{ k}\Omega$
Connection	output I: terminals 7-, 8+ output II: terminals 10-, 11+
Fault signal	downscale 0 V or 0.5 V, upscale 5.375 V
Transfer characteristics	
Deviation	
After calibration	<u>Pt100</u> : $\pm (0.06 \%$ of measurement value in K + 0.1 K (4-wire connection)) <u>thermocouple</u> : $\pm (0.05 \%$ of measurement value in $^{\circ}\text{C}$ + 1 K (1.2 K for types R and S)) this includes $\pm 0.8 \text{ K}$ error of the cold junction compensation <u>mV</u> : $\pm 50 \mu\text{V}$ <u>potentiometer</u> : $\pm 0.05 \%$ of full scale, (excludes errors due to lead resistance) <u>output</u> : 1 to 5 V output: $\pm 4 \text{ mV}$ from 0 to 103.1 % of span; 0 to 5 V output: $\pm 4 \text{ mV}$ from 0.3 to 102.5 % of span
Influence of ambient temperature	deviation of CJC included: <u>Pt100</u> : $\pm (0.0015 \%$ of measurement value in K + 0.0075 % of span)/K ΔT_{amb} ^{*)} <u>thermocouple</u> : $\pm (0.02 \text{ K} + 0.005 \%$ of measurement value in $^{\circ}\text{C}$ + 0.0075 % of span)/K ΔT_{amb} ^{*)} <u>mV</u> : $\pm (0.01 \%$ of measurement value + 0.0075 % of span)/K ΔT_{amb} ^{*)} <u>potentiometer</u> : $\pm 0.0075 \%$ of span/K ΔT_{amb} ^{*)} ^{*)} ΔT_{amb} = ambient temperature change referenced to 23 $^{\circ}\text{C}$ (296 K)
Influence of supply voltage	$< 0.01 \%$ of span
Reaction time	worst case value (sensor breakage and/or sensor short circuit detection enabled) mV: 1.2 s, thermocouples with CJC: 1.4 s, thermocouples with fixed ref. temp: 1.4 s, 3- or 4-wire RTD: 1.1 s, 2-wire RTD: 920 ms, Potentiometer: 3-wire connection 2.8 s, 2-wire connection 2.25 s
Galvanic isolation	
Output/supply, programming input	functional insulation, rated insulation voltage 50 V AC There is no electrical isolation between the programming input and the supply. The programming cable provides galvanic isolation so that ground loops are avoided.
Indicators/settings	
Display elements	LEDs
Configuration	via PACTware
Labeling	space for labeling at the front
Directive conformity	
Electromagnetic compatibility	
Directive 2014/30/EU	EN 61326-1:2013 (industrial locations)
Conformity	
Electromagnetic compatibility	NE 21:2006
Degree of protection	IEC 60529:2001

Release date 2019-01-25 09:38 Date of issue 2019-01-25 248768_eng.xml

Protection against electrical shock	UL 61010-1:2004
Ambient conditions	
Ambient temperature	-20 ... 60 °C (-4 ... 140 °F)
Mechanical specifications	
Degree of protection	IP20
Connection	screw terminals
Mass	approx. 130 g
Dimensions	20 x 119 x 115 mm (0.8 x 4.7 x 4.5 inch) , housing type B2
Mounting	on 35 mm DIN mounting rail acc. to EN 60715:2001
Data for application in connection with hazardous areas	
EU-Type Examination Certificate	CESI 04 ATEX 143
Marking	ⓧ II (1)G [Ex ia Ga] IIC ⓧ II (1)D [Ex ia Da] IIIC ⓧ I (M1) [Ex ia Ma] I
Input	Ex ia
Inputs	terminals 1, 2, 3, 4, 5, 6 (for passive equipment)
Voltage	U _o 9 V
Current	I _o 22 mA
Power	P _o 50 mW
Analog outputs, power supply, collective error	
Maximum safe voltage	U _m 250 V (Attention! This is not the rated voltage.)
Interface	
Maximum safe voltage	U _m 250 V (Attention! The rated voltage is lower.), RS 232
Certificate	TÜV 02 ATEX 1797 X
Marking	ⓧ II 3G Ex nA II T4
Galvanic isolation	
Input/Other circuits	safe electrical isolation acc. to IEC/EN 60079-11, voltage peak value 375 V
Directive conformity	
Directive 2014/34/EU	EN 60079-0:2012+A11:2013 , EN 60079-11:2012 , EN 60079-15:2010 , EN 50303:2000
International approvals	
UL approval	
Control drawing	116-0410
CSA approval	
Control drawing	116-0314 (cCSAus) 116-0347
IECEX approval	
IECEX certificate	IECEX TUN 07.0003 IECEX CML 16.0126X
IECEX marking	[Ex ia Ga] IIC , [Ex ia Da] IIIC , [Ex ia Ma] I Ex nA IIC T4 Gc
General information	
Supplementary information	Observe the certificates, declarations of conformity, instruction manuals, and manuals where applicable. For information see
Accessories	
Optional accessories	- power feed module KFD2-EB2(.R4A.B)(.SP) - universal power rail UPR-03(-M)(-S) - profile rail K-DUCT-BU(-UPR-03) - FDT framework PACTware 4.1 - device type manager DTM Interface Technology - adapter K-ADP-USB-AB

Release date 2019-01-25 09:38 Date of issue 2019-01-25 248768_eng.xml